

RL1521A Single Point, Aluminum NTEP 1:5000 Class III Single Cell

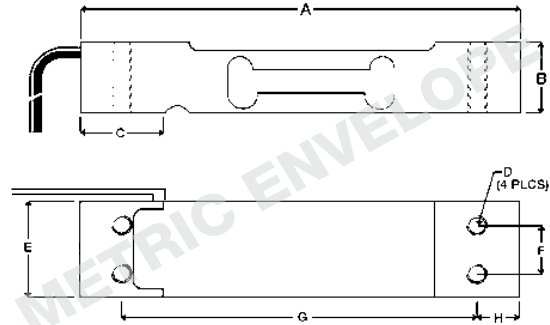

Picture is a representation of actual product



SPECIFICATIONS

Full Scale Output:
2.0 mV/V

Output Resistance:
350 ohm +/- 3

Input Resistance:
415 ohms +/- 15

Material/Finish:
Aluminum

Temperature:
Compensated range
14°F to 104°F/-10°C to 40°C

Safe Overload:
150% Full scale

Rated Excitation:
10V DC (15V maximum)

Total Error:
0.03% Full scale

Insulation Resistance:
2000 megohms

Seal Type:
Environmentally sealed

Cable Length:
1.50 ft/.5m
10 ft/3.1 m

Cable Diameter:
.14 PVC jacket

Cable Color Code:
Green..... + Excitation
Black..... - Excitation
Red..... + Signal
White..... - Signal

Max Platform Size:
13.75 in x 13.75 in

Warranty:
Two-year limited warranty

Approvals:



DIMENSIONS

RATED CAPACITY	A	B	C	D	E	F	G	H
kg/mm								
3-7	130.0	22.0	25.0	M6 x 1.0	25.4	15.0	106.0	12.0
10-30	130.0	22.0	25.0	M6 x 1.0	30.0	15.0	106.0	12.0
35	130.0	22.0	25.0	M6 x 1.0	40.0	15.0	106.0	12.0
lb/inches								
6.6-15.4	5.12	.87	.99	M6 x 1.0	1.00	.59	4.17	.47
22.0-66.2	5.12	.87	.99	M6 x 1.0	1.18	.59	4.17	.47
77.2	5.12	.87	.99	M6 x 1.0	1.57	.59	4.17	.47

ORDER INFORMATION: 1.50' CABLES

LOAD RATING	PART #	PRICE
3 kg (6.6 lb)	50620	Consult
5 kg (11 lb)	50619	Consult
7 kg (15.4 lb)	50621	Consult
10 kg (22 lb)	50622	Consult
15 kg (33.1 lb)	50623	Consult
20 kg (44.1 lb)	50624	Consult
30 kg (66.1 lb)	50625	Consult
35 kg (110.2 lb)	50626	Consult

INTERCHANGEABLE PRODUCTS

MANUFACTURER	MODEL	PAGE #
VPG Celtron	LPS except 3kg	204
VPG BLH	C2G1	—
Fairbanks®	4900 Series Checkweighers	—
NMB®	C2G1	—
VPG Tedeo-Huntleigh	1022	332
Artech®	61022	—

ORDER INFORMATION: 10' CABLES

LOAD RATING	PART #	PRICE
3 kg (6.6 lb)	132261	Consult
5 kg (11 lb)	132262	Consult
7 kg (15.4 lb)	132263	Consult
10 kg (22 lb)	132264	Consult
15 kg (33.1 lb)	132265	Consult
20 kg (44.1 lb)	132266	Consult
30 kg (66.1 lb)	132267	Consult
35 kg (110.2 lb)	132268	Consult

RICE LAKE WEIGHING SYSTEMS

